

WE BRING IT ALL TOGETHER

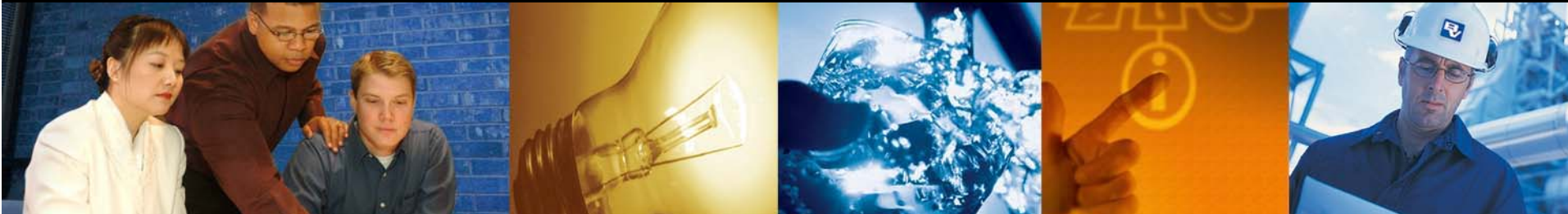

Overview of Thermochemical Biorefinery Technologies

Jon C. Erickson, P.E., CEM
Manager of Engineering, Industrial Energy
Black & Veatch



Confidential information. ©Copyright Black & Veatch Corporation, 2005. All rights reserved.

August 28, 2006



Typical Thermochemical Biorefinery Products

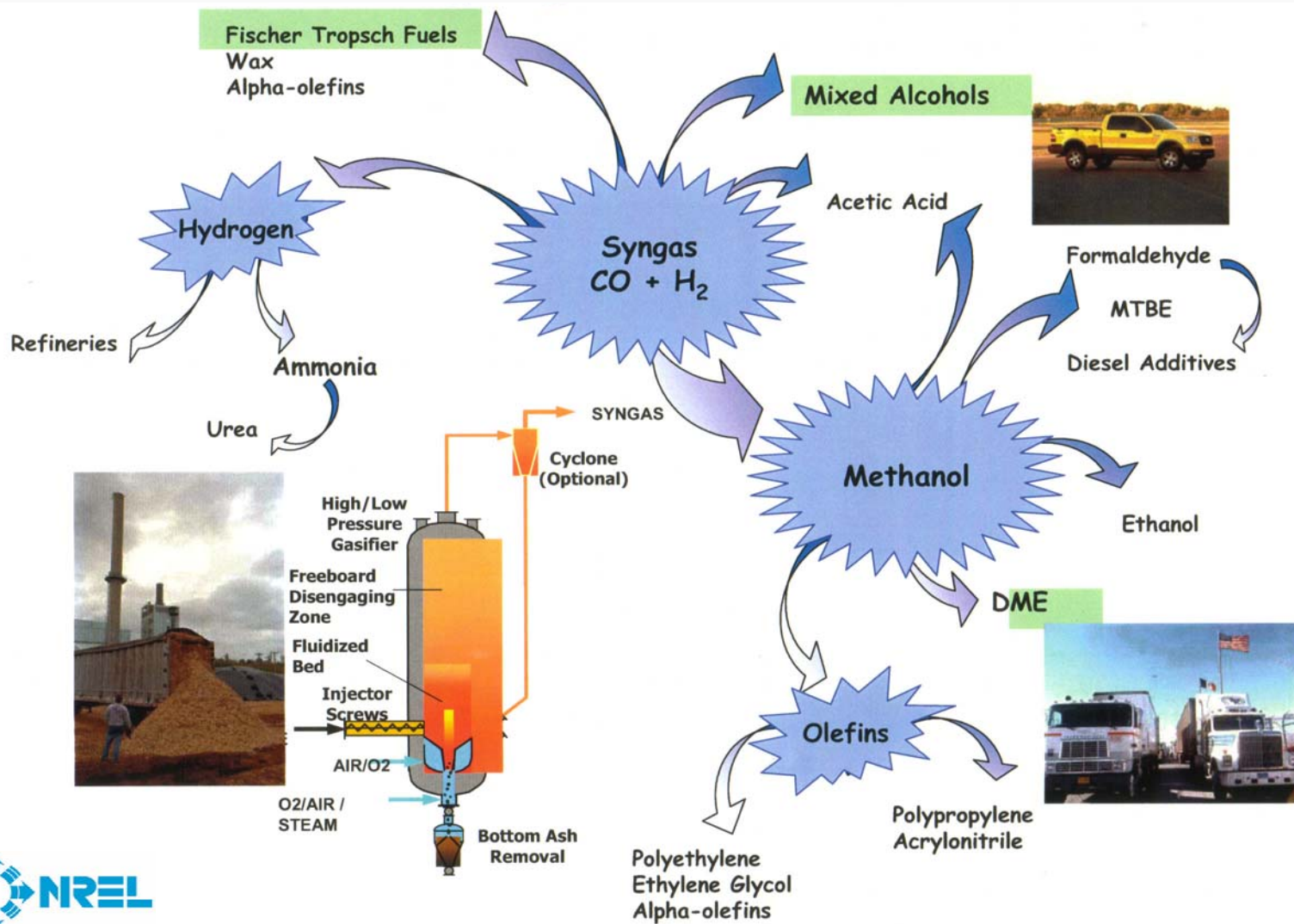



Typical Flow Diagram of Thermochemical Biorefinery Producing Alcohols

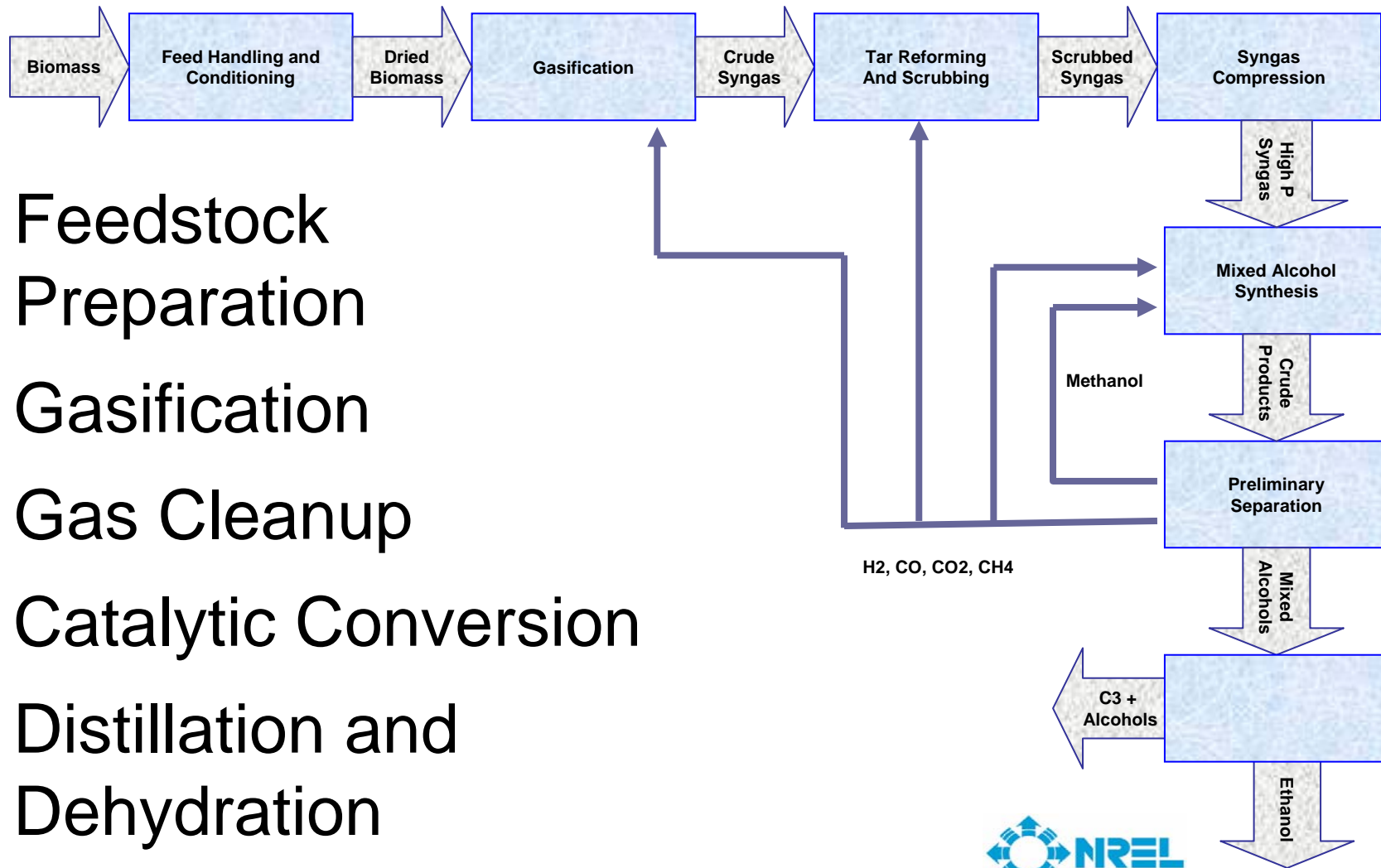

- Feedstock Preparation
- Gasification
- Gas Cleanup
- Catalytic Conversion
- Distillation and Dehydration





Efficient Biomass Gasifiers Exploit the Unique Characteristics of Biomass

Characteristic

Fibrous Material



Implications

Feeding Systems

- Particle Size Limitations, Pressurized Operation More Difficult

High Reactivity

- High Volatiles Content
- High Char Reactivity



Gasifier Design

- Allows Gasification Without Pure Oxygen

Raw Syngas Composition

- Tars
- Sulfur
- Alkali, Ammonia, Others



Gas Cleanup

- More Tar, Water Soluble
- Low Sulfur (Except BL)
- Must Be Considered

Scale of Operation



Limits Economies of Scale





Direct Gasifier Types

1. Updraft
2. Downdraft
3. Fluidized Bed
 - Bubbling
 - Circulating Flow
4. Entrained Flow
5. Staged Steam Reformation



Updraft Gasifier

- Simple, Reliable
- Commercial History
- High Tars
- Close Coupled Combustion

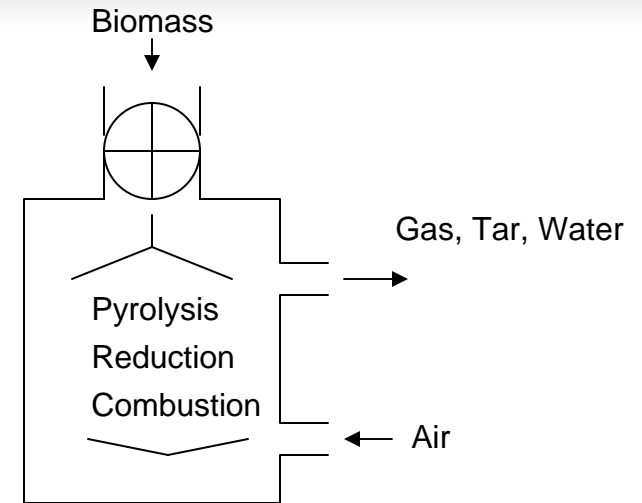
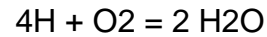
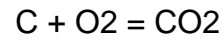
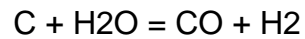
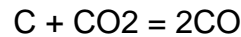

Source: Renewable Energy Corp. Ltd



Downdraft Gasifier

- Requires Low Moisture (<20%)
- Low Tars
- Can Use Gas in Engines (After Conditioning)

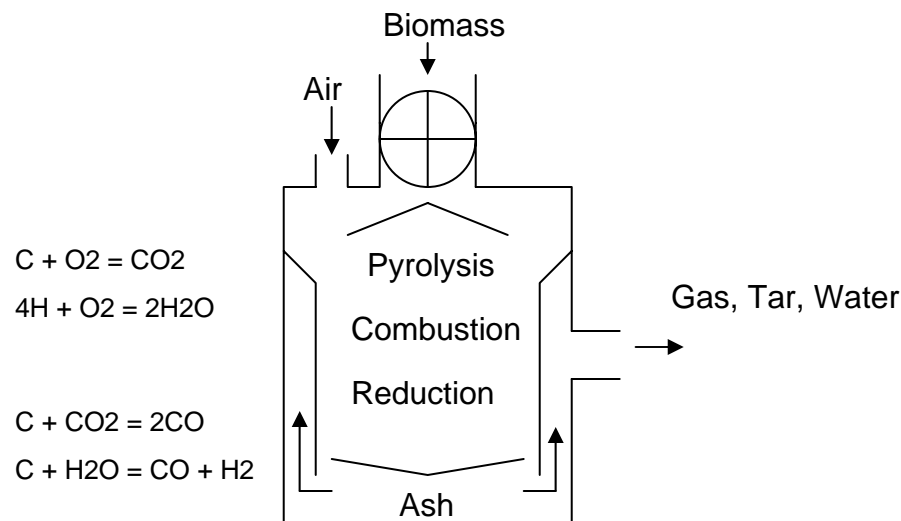



Fluidized Bed Gasifier

- Highest Throughput
- Fuel Flexible
- Tolerates Moisture
- Complex Operation

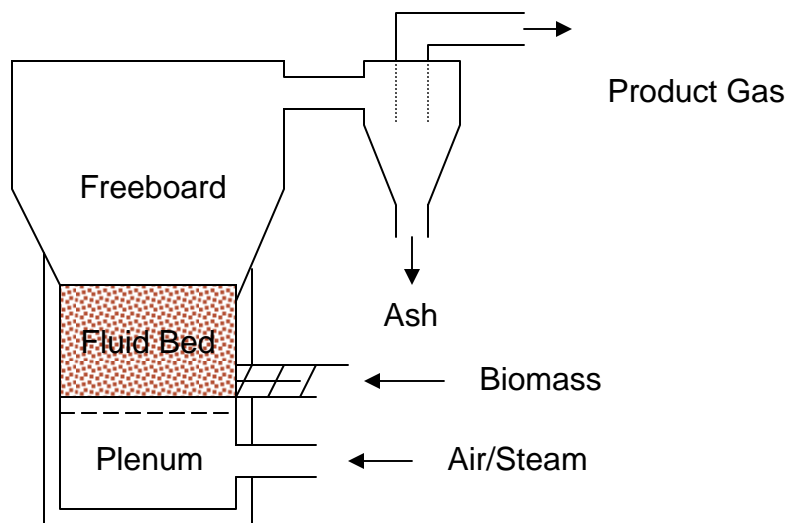



Entrained Gasifier

- Requires Low Moisture (<20%)
- Low Tars
- Can Use Gas in Engines (After Conditioning)

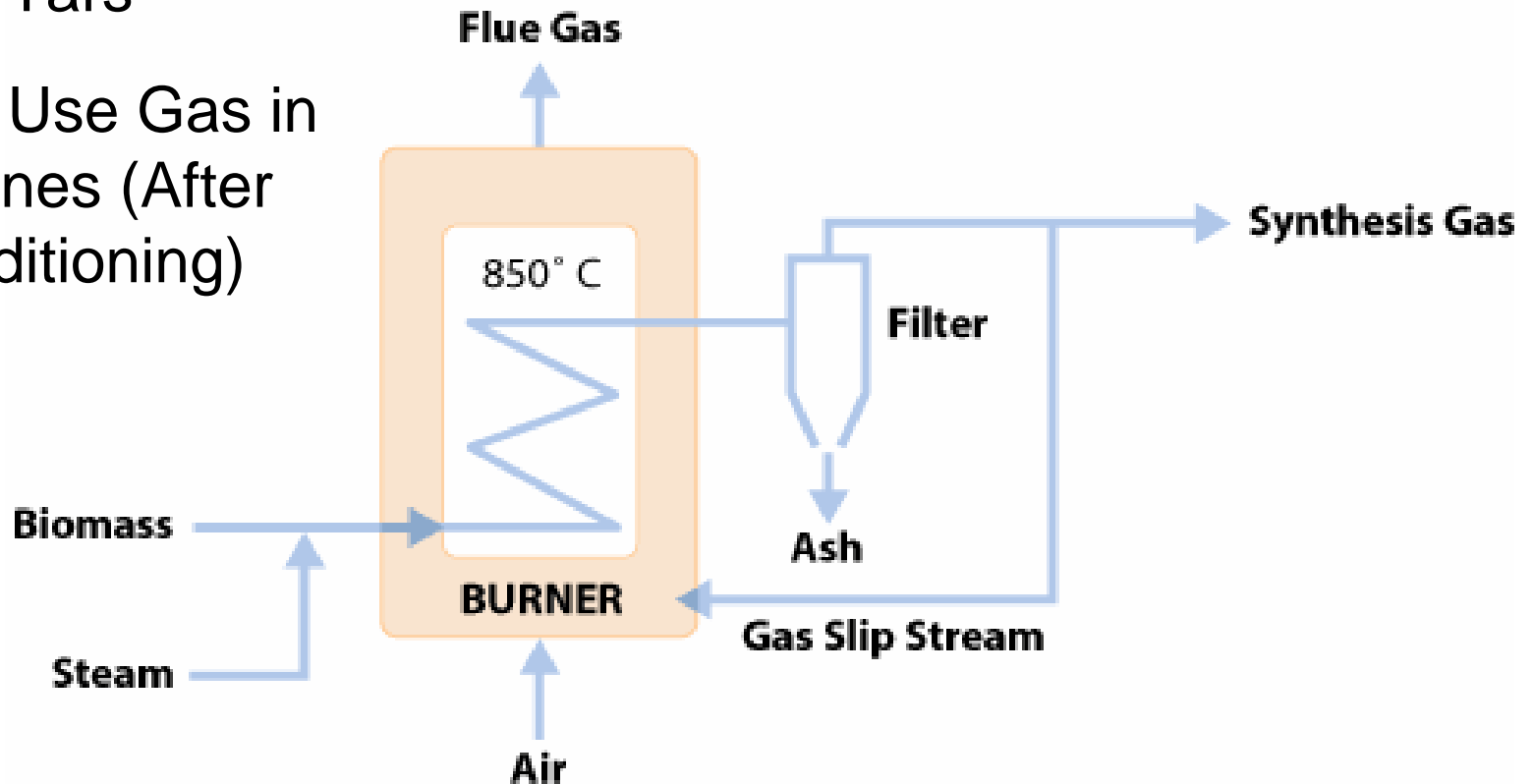



Staged Steam Reformation With a Screw Auger Gasifier

- Low Tars
- Scalability issues
- Can Use Gas in Engines (After Conditioning)

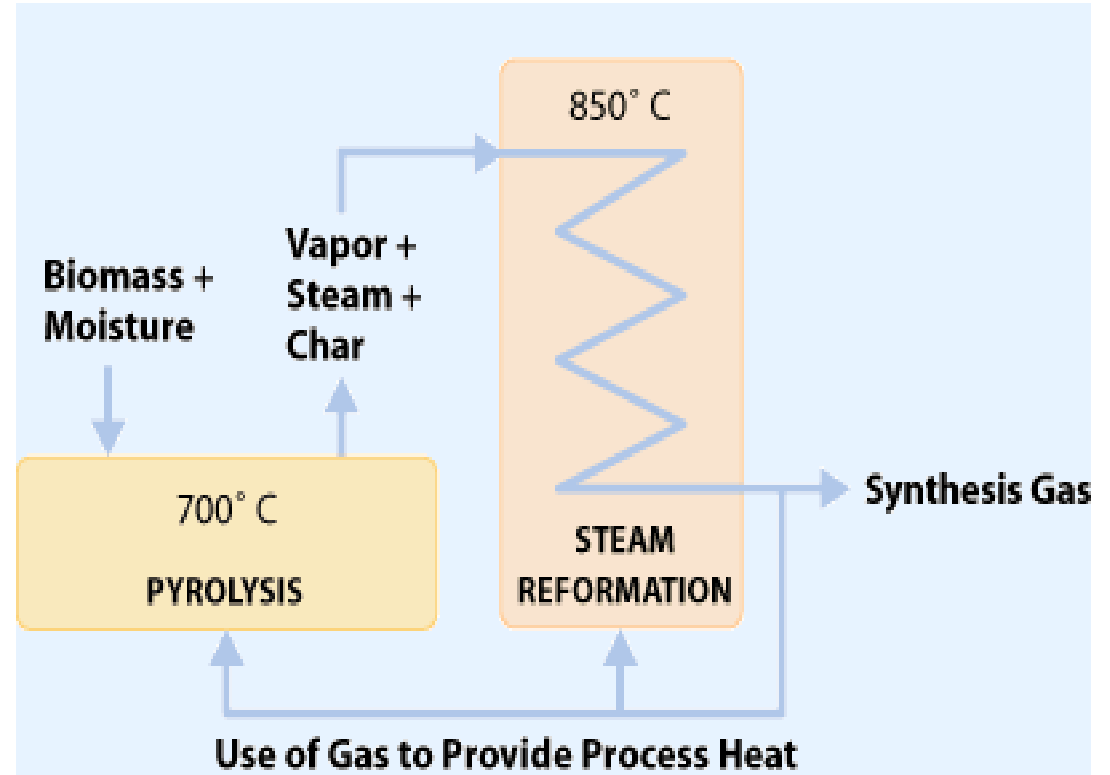



Thermochemical Conversion of Biomass

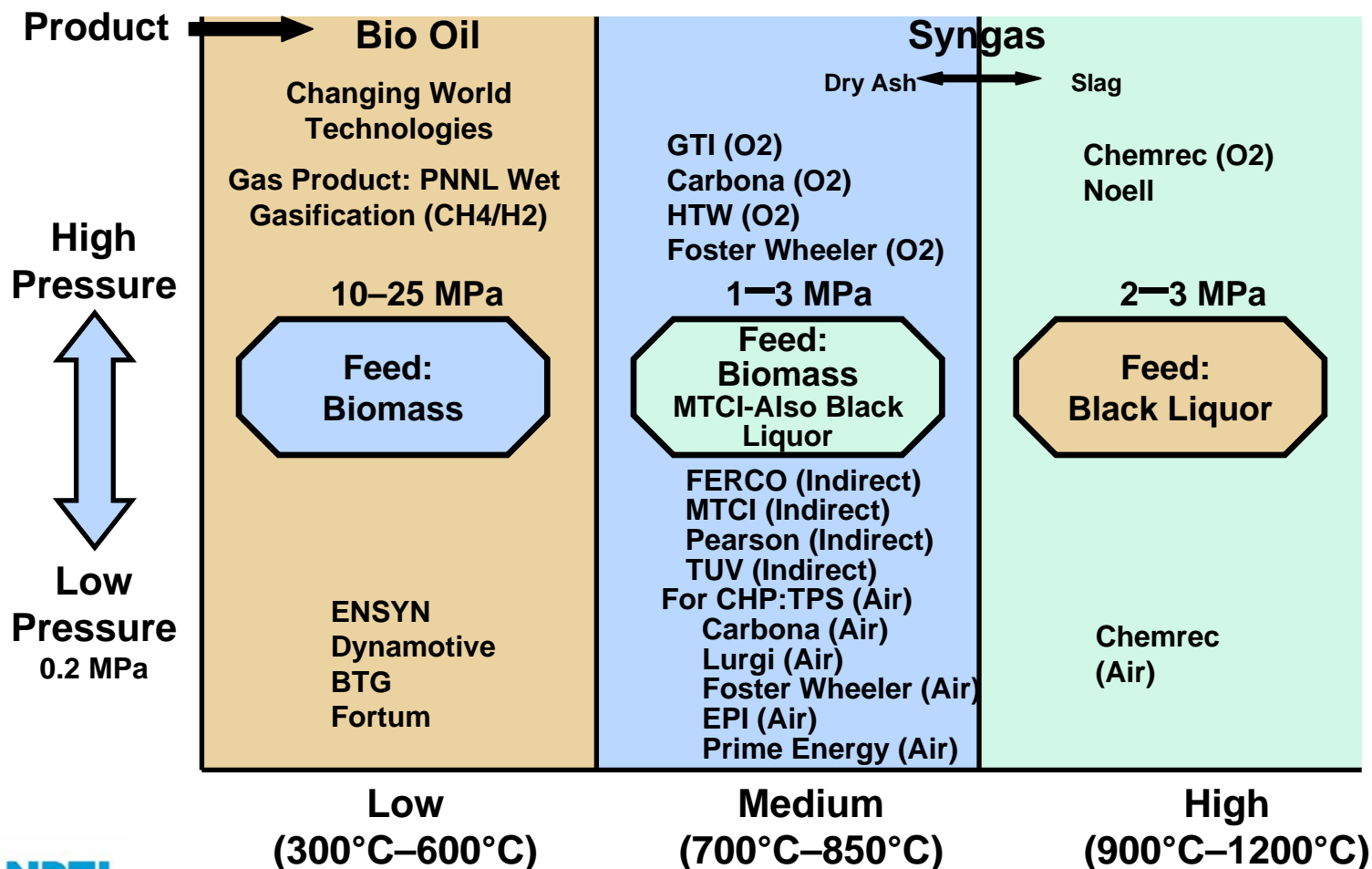



Syngas to High Value Products

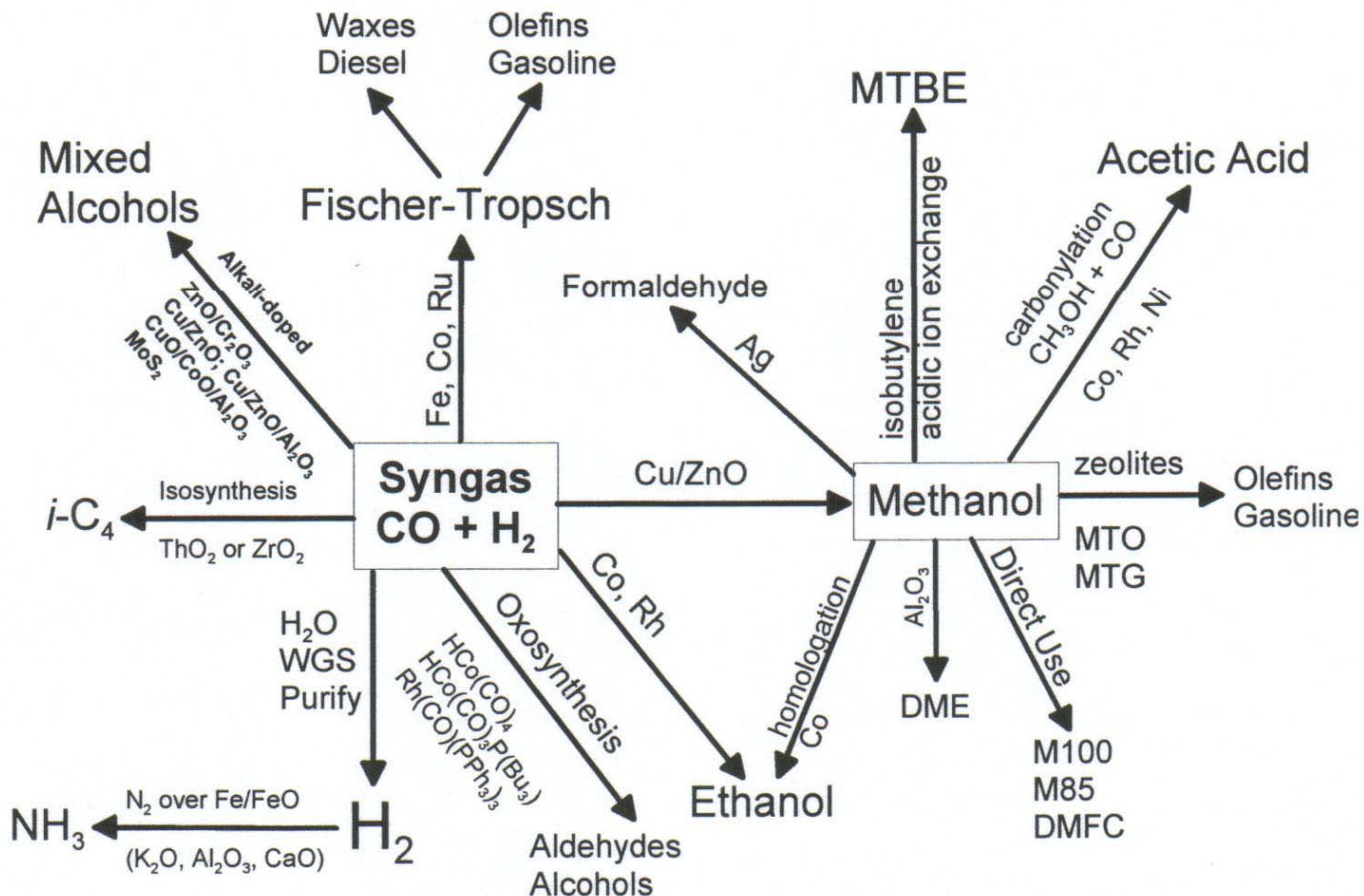



Fischer-Tropsch Reactions

Three Major Steps:

1. Initiation on Catalyst Surface
2. Hydrocarbon Chain Growth
3. Chain Termination



Fischer-Tropsch Product Distribution

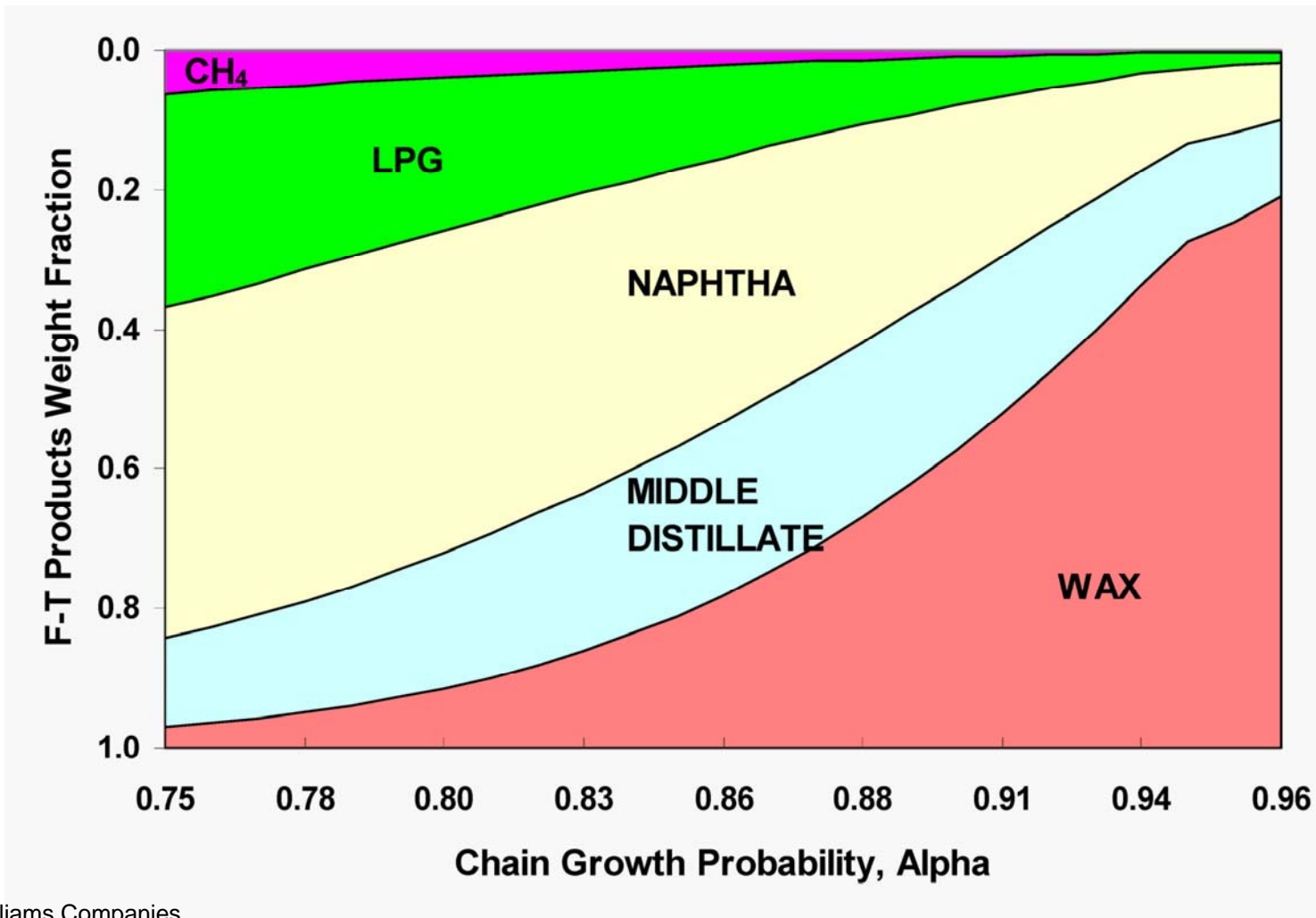

Source: Williams Companies



Fischer-Tropsch Product Composition

Product Composition Strongly Influenced by:

- Catalyst Composition
- Syngas H₂ to CO Ratio (~ 2.0 to 1)
- Operating Conditions



Reactor Types

Fixed Bed Reactor

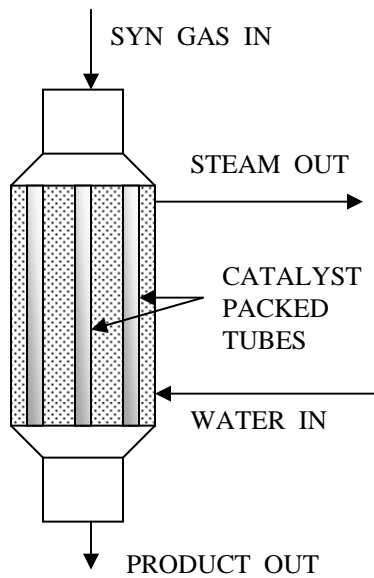

Slurry Bubble Column Reactor

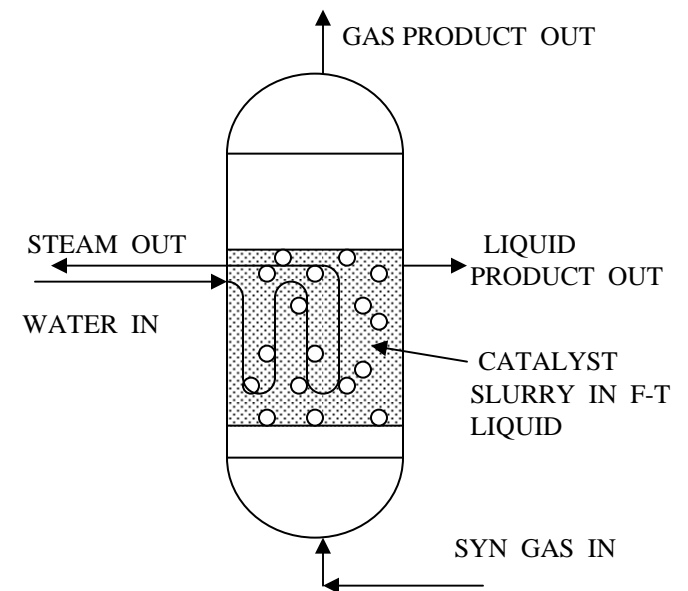

Fluidized Bed Reactor

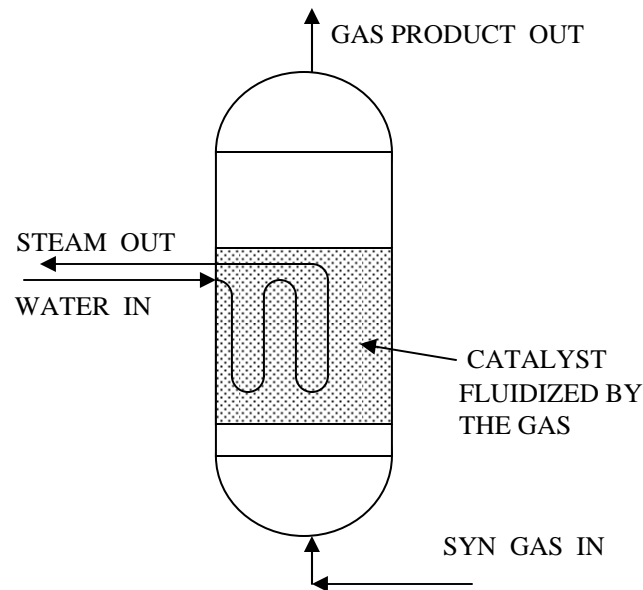



Catalytic Conversion of Syngas to Alcohols

Methanol Production



Ethanol Production

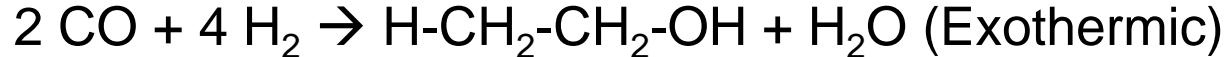

Side Reactions





Alcohol Reactor Schematic

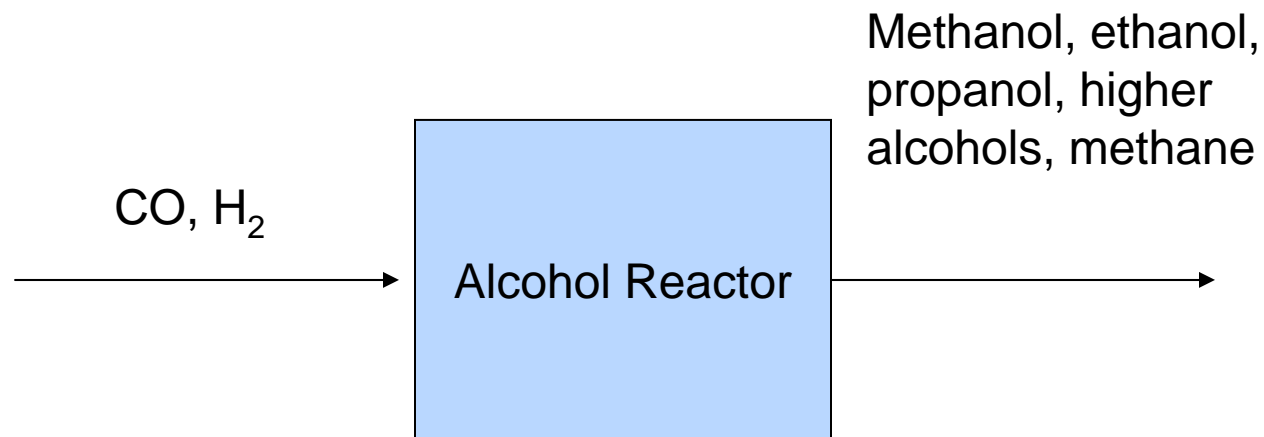

- Selectivity Ranges: 30% - 90%
- Conversion Ranges: 5% - 60%
- Alcohol Ranges: Mostly C1 – C4
- Pressures Up to 2600 psig



Cost of Ethanol via Gasification

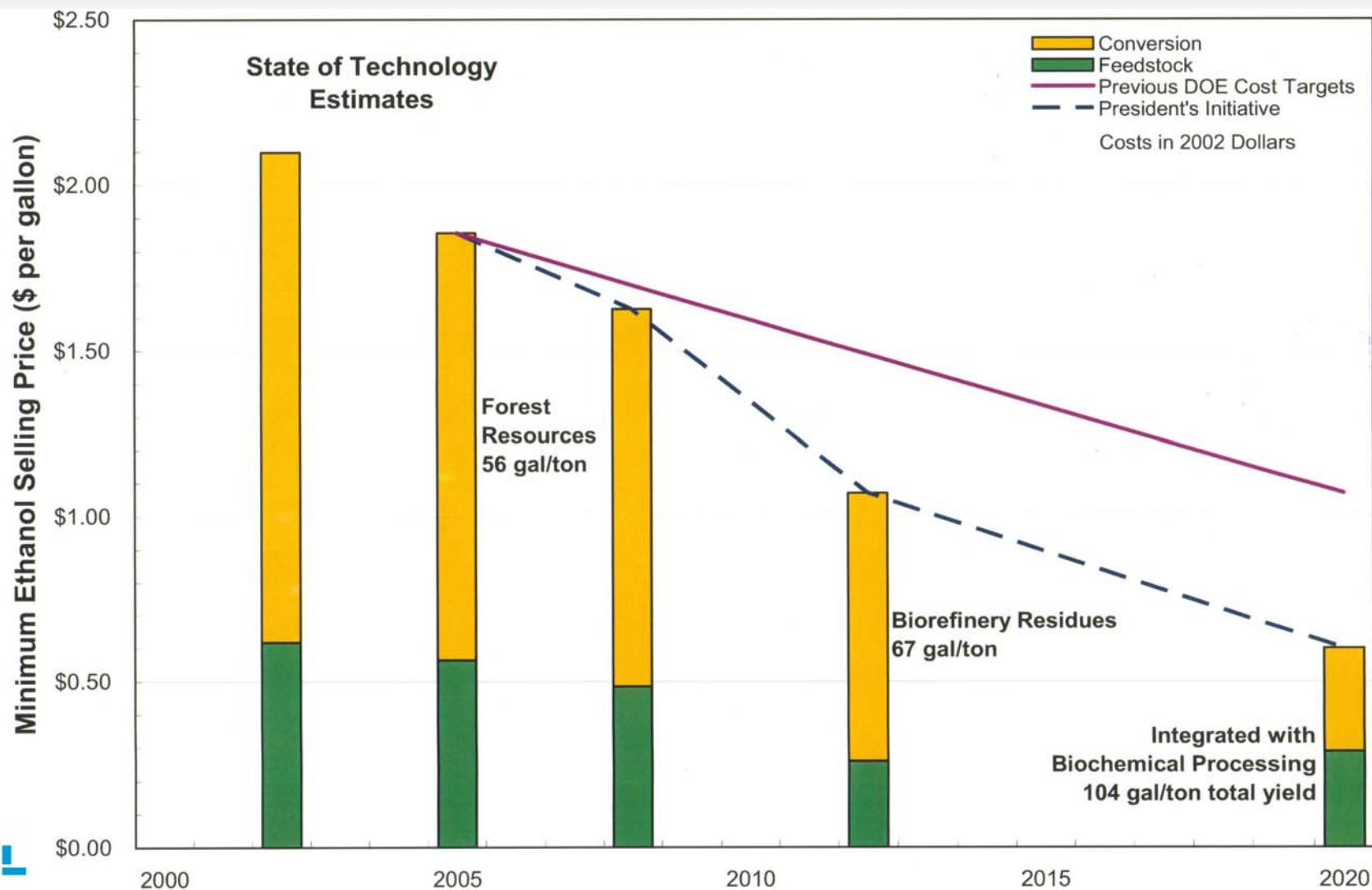



Status of Thermochemical Biomass to Ethanol

- **DOE Funding Opportunity**-Commercial Demonstration of an Integrated Biorefinery System for Production of Liquid Transportation Biofuels, Biobased Chemicals, Substitutes for Petroleum-Based Feedstocks and Products, and Biomass-Based Heat / Power
 - Validated Pilot Plant Data
 - Material and Energy Balances (Simulation)
 - Equipment Requirements
 - Project Work Plan (Schedule and Budget)
 - Project Pro Formas
 - Deployment Plan



Catalytic Options for Different High Value Products

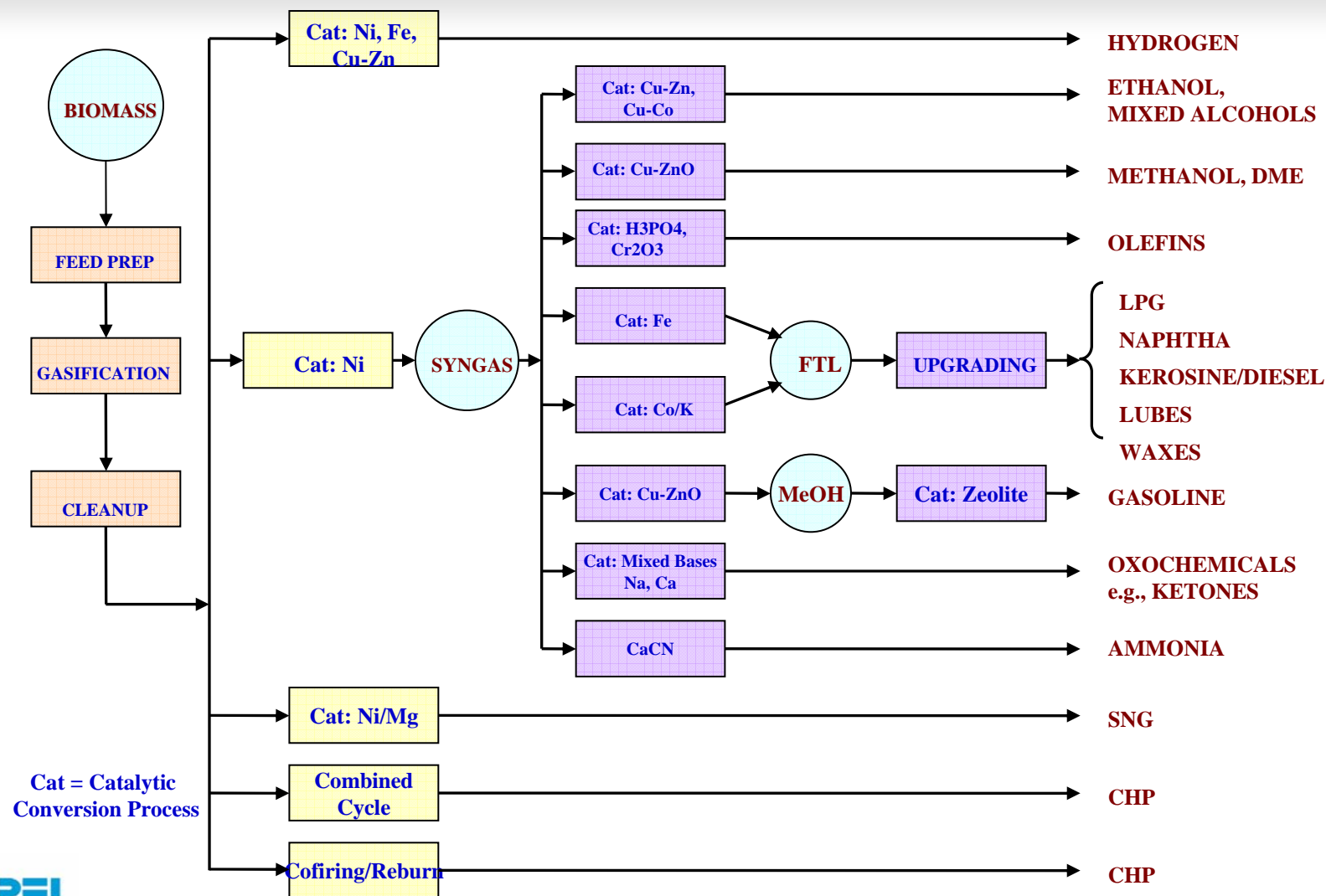



Thermochemical Biorefinery

